

22-3 Counter stay



DESCRIPTION

Counter stays from the 22 series are used together with internal extractors from the 21 series in trade, industry and workshops. Counter stays are particularly suitable for large cylinder liners and ball bearings etc. thanks to the ribbed shape of the support feet and ensure a firm stand when extracting. This improves the gentle extraction of internal parts.

RANGE OF APPLICATION

Together with internal extractors of the series 21

BENEFIT

- Sizes from 21-2 are particularly low-friction due to thrust bearings integrated in the mould
- The frictional resistance of the Counterstays Nut is minimised by a built-in thrust bearing

OPERATION

- Determine the internal diameter of the Ball bearing and select a suitable Internal extractor
- Insert the Internal extractors into the bore and tighten the clamping nut
- Support the Counter stay on the housing and screw it onto the wedge spindle of the Internal extractor
- Hold the handle of the Counterstays and pull out the bearing safely by tightening the hexagon nut
- Retighten the clamping nut when pulling out

MASTER DATA

GTIN [EAN]	4021176012488
Country of origin	DE
Case material	Tool steel
Series	22
Gross weight [kg]	4 kg
Package contents	1 piece
Packaging Act	PAP 21
Global sales capability given	Yes

SPARE PARTS

- 22-3-T_Traverse
- 022-306_Ersatzspindel
- 22-3-1-P_2 Pulling jaws (pair)

APPLICATION IMAGE



Counter stay

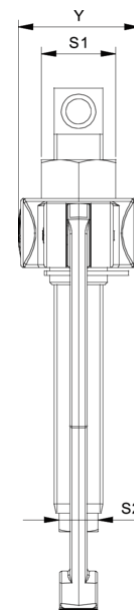
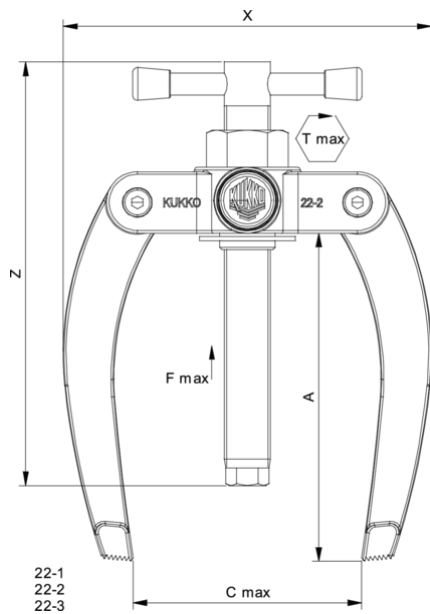

Abbreviation	Attribut	Wert
X	Total width [mm]	260 mm
Y	Total depth [mm]	51 mm
S1	Width across flats [mm]	32 mm
Fmax	Max. tractive force [t]	5 t
Fmax	Max. tensile force [kN]	50 kN
A	Clamping depth [mm]	280 mm
T1	External thread of the spindle [nominal dimension]	G 1/2
T2	Internal thread of the spindle [nominal dimension]	G 1/2, 15-16 G

Abbreviation	Attribut	Wert
X	Total width [mm]	260 mm
Y	Total depth [mm]	51 mm
S1	Width across flats [mm]	32 mm
Fmax	Max. tractive force [t]	5 t
Fmax	Max. tensile force [kN]	50 kN
A	Clamping depth [mm]	280 mm
T1	External thread of the spindle [nominal dimension]	G 1/2
T2	Internal thread of the spindle [nominal dimension]	G 1/2, 15-16 G

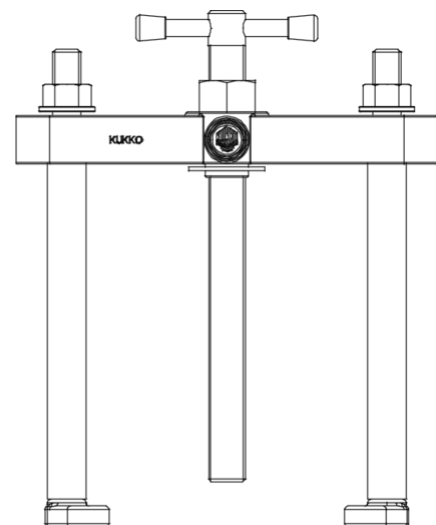
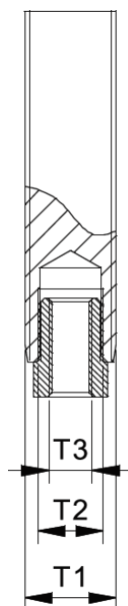

22-4
22-5

Abbreviation	Attribut	Wert
--------------	----------	------

Abbreviation	Attribut	Wert
--------------	----------	------

X	Total width [mm]	260 mm
Y	Total depth [mm]	51 mm
S1	Width across flats [mm]	32 mm
Fmax	Max. tractive force [t]	5 t
Fmax	Max. tensile force [kN]	50 kN
A	Clamping depth [mm]	280 mm
T1	External thread of the spindle [nominal dimension]	G 1/2
T2	Internal thread of the spindle [nominal dimension]	G 1/2, 15-16 G

X	Total width [mm]	260 mm
Y	Total depth [mm]	51 mm
S1	Width across flats [mm]	32 mm
Fmax	Max. tractive force [t]	5 t
Fmax	Max. tensile force [kN]	50 kN
A	Clamping depth [mm]	280 mm
T1	External thread of the spindle [nominal dimension]	G 1/2
T2	Internal thread of the spindle [nominal dimension]	G 1/2, 15-16 G