

20-10+S 2-jaw universal puller with narrow, quickly adjustable pulling jaws



APPLICATION IMAGE



DETAIL IMAGE



DESCRIPTION

The 2-jaw universal puller with narrow adjustable pulling jaws is used for the safe and user-friendly pulling of bearings, gears and discs in all common sizes for trades, workshops and industry. It can be used to remove any component that sits on a shaft and is freely accessible from the outside. The narrow pulling jaws ensure that even narrow and difficult to access spaces can be reached.

RANGE OF APPLICATION

For safe and user-friendly extraction of bearings, gears and pulleys

BENEFIT

- Narrow pulling jaws grip optimally in narrow and poorly accessible spaces
- Easy, manual release of the pulling jaws by means of turning the manually adjustable wheel (Quick Adjust Technology)
- Easy application also with eccentric components due to free-moving pulling jaws sliding off the crossbar
- Hexagon drive on the crossbeam, for safe counter holding
- Quick-adjustable Pulling hooks guarantee immediate adjustment to any span between 4 mm - 120 mm
- Shear-resistant suspension of the claw in the slide piece (Armlock Technology)
- Secure positioning of the Spindle thanks to the rotatable spindle tip, both on smooth surfaces and when centring (Switch Technology)
- Optionally convertible from an external extractor to an internal extractor by reversing the pulling jaws
- Anti-slip guard on the spindle head for safe working with wrench
- Spindle riser protects the threading

OPERATION

- Place the Pulling jaws on the part to be extracted from the outside
- Slide the claws under the component
- Use the hand knurl to manually fasten the hooks
- Manually pull the Spindle to apply pressure for fixing
- Move the hexagon on the spindle head with a ratchet or combination spanner until the component is released

MASTER DATA

GTIN [EAN]	4021176756306
Country of origin	DE
Case material	Tool steel
Series	20+S
Gross weight [kg]	1,42 kg
Package contents	1 piece
Packaging Act	PAP 21
Global sales capability given	Yes

SPARE PARTS

- 1-93-P_Slim, quickly adjustable pulling jaws (pair)
- 614160_Mechanical pressure spindle
- 20-10-T_Traverse for 20-10
- 612140_Two-sided spindle tip

2-jaw universal puller with narrow, quickly adjustable pulling jaws

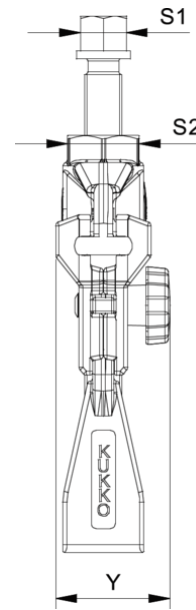
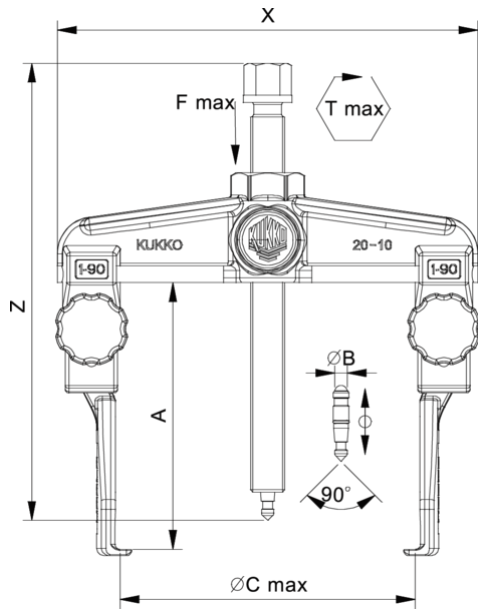

Abbreviation	Attribut	Wert
X	Total width [mm]	172 mm
Y	Total depth [mm]	50 mm
Z	Total height [mm]	183 mm
A	Clamping depth outside pull-off [mm]	100 mm
S1	Width across flats [mm]	17 mm
S2	Width across flats [mm]	27 mm
Cmin	Span outside pull-off (min.) [mm]	4 mm
Cmax	Span outside pull-off (max.) [mm]	120 mm
K	Hook root thickness at the tip (claw thickness K) [mm]	3 mm
J	Hook base width (claw width J) [mm]	30 mm
O	Hook base depth usable (claw depth usable O) [mm]	13 mm
H	Total hook root depth (total claw depth H) [mm]	13 mm
L	Total claw thickness (L+1mm) (claw distance to base surface) [mm]	2,6 mm
Emin	Span inside pull-out (min.) [mm]	70 mm
Emax	Span inside pull-out (max.) [mm]	180 mm
Tmax	Max. torque [Nm]	35 Nm
Fmax	Max. tractive force [t]	2.5 t
Fmax	Max. tensile force [kN]	25 kN

Abbreviation	Attribut	Wert
X	Total width [mm]	172 mm
Y	Total depth [mm]	50 mm
Z	Total height [mm]	183 mm
A	Clamping depth outside pull-off [mm]	100 mm
S1	Width across flats [mm]	17 mm
S2	Width across flats [mm]	27 mm
Cmin	Span outside pull-off (min.) [mm]	4 mm
Cmax	Span outside pull-off (max.) [mm]	120 mm
K	Hook root thickness at the tip (claw thickness K) [mm]	3 mm
J	Hook base width (claw width J) [mm]	30 mm
O	Hook base depth usable (claw depth usable O) [mm]	13 mm
H	Total hook root depth (total claw depth H) [mm]	13 mm
L	Total claw thickness (L+1mm) (claw distance to base surface) [mm]	2,6 mm
Emin	Span inside pull-out (min.) [mm]	70 mm
Emax	Span inside pull-out (max.) [mm]	180 mm
Tmax	Max. torque [Nm]	35 Nm
Fmax	Max. tractive force [t]	2.5 t
Fmax	Max. tensile force [kN]	25 kN

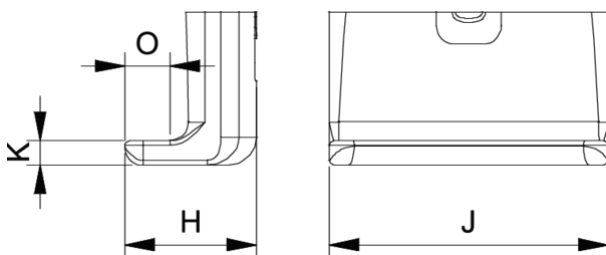

Abbreviation	Attribut	Wert
X	Total width [mm]	172 mm
Y	Total depth [mm]	50 mm
Z	Total height [mm]	183 mm

A	Clamping depth outside pull-off [mm]	100 mm
S1	Width across flats [mm]	17 mm
S2	Width across flats [mm]	27 mm
Cmin	Span outside pull-off (min.) [mm]	4 mm
Cmax	Span outside pull-off (max.) [mm]	120 mm
K	Hook root thickness at the tip (claw thickness K) [mm]	3 mm
J	Hook base width (claw width J) [mm]	30 mm
O	Hook base depth usable (claw depth usable O) [mm]	13 mm
H	Total hook root depth (total claw depth H) [mm]	13 mm
L	Total claw thickness (L+1mm) (claw distance to base surface) [mm]	2,6 mm
Emin	Span inside pull-out (min.) [mm]	70 mm
Emax	Span inside pull-out (max.) [mm]	180 mm
Tmax	Max. torque [Nm]	35 Nm
Fmax	Max. tractive force [t]	2.5 t
Fmax	Max. tensile force [kN]	25 kN

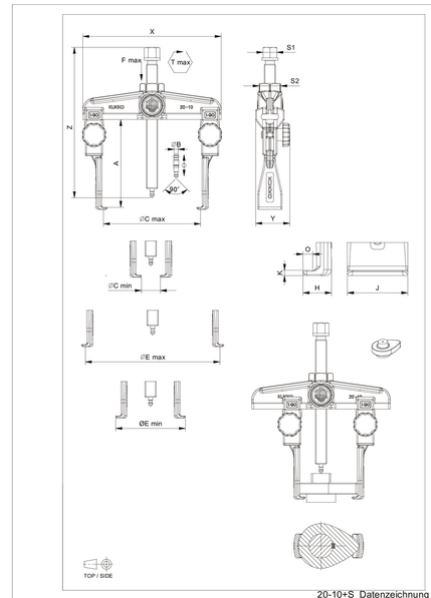

Abbreviation	Attribut	Wert
X	Total width [mm]	172 mm
Y	Total depth [mm]	50 mm
Z	Total height [mm]	183 mm
A	Clamping depth outside pull-off [mm]	100 mm
S1	Width across flats [mm]	17 mm
S2	Width across flats [mm]	27 mm
Cmin	Span outside pull-off (min.) [mm]	4 mm
Cmax	Span outside pull-off (max.) [mm]	120 mm
K	Hook root thickness at the tip (claw thickness K) [mm]	3 mm
J	Hook base width (claw width J) [mm]	30 mm
O	Hook base depth usable (claw depth usable O) [mm]	13 mm
H	Total hook root depth (total claw depth H) [mm]	13 mm
L	Total claw thickness (L+1mm) (claw distance to base surface) [mm]	2,6 mm
Emin	Span inside pull-out (min.) [mm]	70 mm
Emax	Span inside pull-out (max.) [mm]	180 mm
Tmax	Max. torque [Nm]	35 Nm
Fmax	Max. tractive force [t]	2.5 t
Fmax	Max. tensile force [kN]	25 kN