

# PRODUCT DATA SHEET

## LIFTING ANCHOR

### PRODUCT DESCRIPTION

The Lifting Anchor is specifically designed for use with a ball supporting bolt. The lifting anchor can be used to transport prefabricated wall modules. The fact that it is used with screws means the anchor can be used several times.



### ADVANTAGES

- Simple assembly
- Reusable
- Can be used in Glue-laminated timber beams and cross-laminated timber
- Transporting large loads

### MATERIAL

- SJ235

### CERTIFICATION



#### Attention

This product is subject to important conditions! Please also watch our video at <https://www.eurotec.team/wissen/mediathek/hebanker-hebefix> follow the instructions for use.



# PRODUCT DATA SHEET

# LIFTING ANCHOR

## TECHNICAL INFORMATION

Lifting Anchor

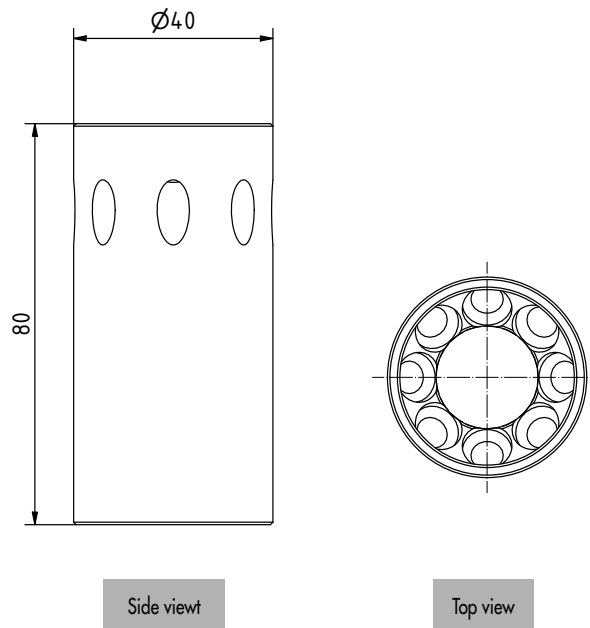

Ball supporting bolt

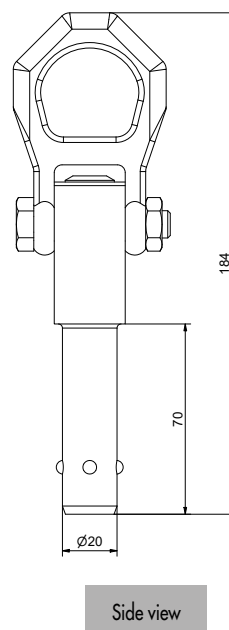

# PRODUCT DATA SHEET

# LIFTING ANCHOR

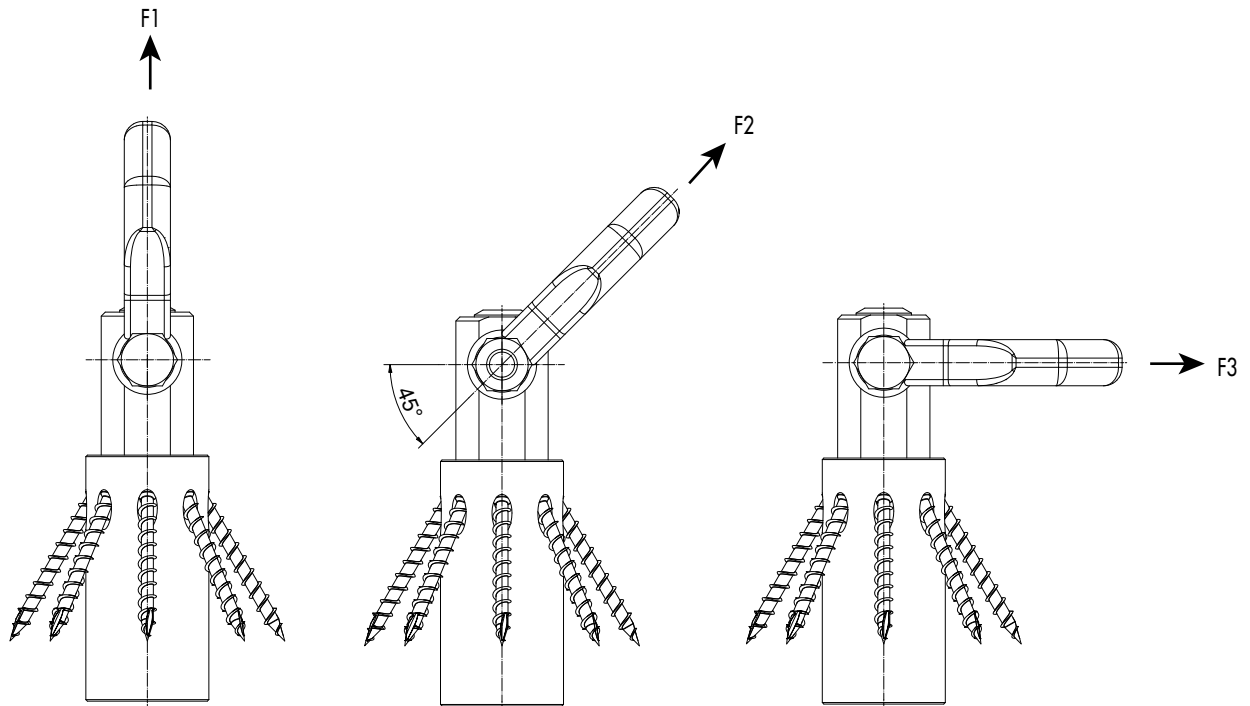

$F_1$ kN*	$F_2$ kN*	$F_3$ kN*
10,0	8,5	6,5

\*with five-fold protection against breakage

# PRODUCT DATA SHEET

# LIFTING ANCHOR

## OPERATING INSTRUCTIONS FOR THE BALL SUPPORTING BOLT

### Warning!

Ball supporting bolts are designed for lifting and holding individual loads (**not people!**). In addition, they are not suitable for continuous load rotation. Contamination (e.g. grinding sludge, oil and emulsion deposits, dust, etc.) can impair the function of ball supporting bolts.

Damaged ball supporting bolts can put people's lives at risk. Before each use, ball supporting bolts must be inspected for visible defects (e.g. deformations, fractures, cracks, damage, missing balls, corrosion, function of the unlocking mechanism). Damaged ball supporting bolts must be withdrawn from further use. The ball carrier bolts have been tested by TÜV.



## HANDLING AND LOADING

Press the button (A) to release the balls. The balls are locked again by releasing the button (A).

**Please note: The button (A) is locked when the spring force has caused it to spring back to its original position. Do not press the button when loaded!**

The load values F1 / F2 / F3 (see page 2) apply to lifting in a steel receptacle and  $x_{min.} = 1.5 \text{ mm}$ .

## MAINTENANCE

Ball supporting bolts must be subjected to a safety inspection by a competent person at least once a year.

## VISUAL INSPECTION

Deformations, fractures, cracks, missing / damaged balls, corrosion, screw connection damage on the shackle.

## FUNCTIONAL TEST

The balls' locking and unlocking mechanism must close automatically by spring force. Full shackle mobility is guaranteed.

## USE

The Lifting Anchor must only be used by competent staff.



# PRODUCT DATA SHEET

# LIFTING ANCHOR

## ORIGINAL EC CONFORMITY MARK

The product complies with the regulations set down in the EC Directive 2006/42/EC.



Manufacture\*: Erwin Halder KG  
Address\*: Erwin-Halder-Straße 5-9  
88480 Achstetten-Bronnen  
Germany

Make: Ball supporting bolt  
Type: EH 22350  
Applied standards: DIN EN 13155

*S. Halder*

Achstetten-Bronnen, December 22, 2016

Stefan Halder, General Manager

\*Responsible for documentation

## MAINTENANCE INSTRUCTIONS HOISTING DEVICE

### MAINTENANCE:

The hoisting device must be subjected to a safety inspection by a competent person at least once a year.

### VISUAL INSPECTION:

The hoisting device must be checked before each use. If there are any indentations in the material due to the ball bearing bolt, corrosion, fractures, damages, tears and deformations of any kind, the hoisting device must be replaced. Contamination (e.g. grinding sludge, oil and emulsion deposits, dust, etc.) can impair the function of the hoisting device. In case of contamination, the component must be cleaned. Standard commercial cleaning agents can be used. Lubricants must be avoided.

## INSTRUCTIONS FOR USE

The S235JR grade steel hoisting device, in accordance with EN 10025-2, is used to connect wooden structures designed in accordance with EN 1995-1-1:2008 Eurocode 5 - Design of timber structures - Part 1-1: General - Common rules and regulations for the building industry were designed and engineered. It may only be used for static or quasi-static loads. Connections with the Hoisting Device are used as structural timber connections and for the transport and assembly of timber components made of laminated timber or CLT. The minimum cross-section thickness for walls and beams is 100 mm. The minimum distances between the edges of the connectors parallel to the component plane is 200 mm. The values in the table apply to characteristic raw densities of at least 350 kg/m<sup>3</sup> for CLT and 385 kg/m<sup>3</sup> for BSH. The table values are only valid for lifting or assembly states. Do not use a hammer directly to drive the hoisting device into the wood. A separation layer must be used to prevent damage to the hoisting device. The hoisting device may only be used with the corresponding 6 x 60 or longer according to EN14952. The component is zinc-nickel coated. Zinc-nickel coatings are resistant to the initial corrosion of base metals (according to DIN EN ISO 9227) for more than 1000 hours in the salt spray test (NSS).

# PRODUCT DATA SHEET

# LIFTING ANCHOR

HORIZONTAL WALL OR BEAM: SET UPRIGHT, THEN LIFT

Glue-laminated timber beams			
Connection in the	Connector	Stop bracket	Total weight [kg]
Side area	Lifting Anchor Ø 40 mm + 8 x VSS 6 x 60	$\beta$	with two strands
		30°	488
		45°	581
		60°	626
		75°	647
		$\beta$	with n strands
		90°	n x 327

Glue-laminated timber wall			
Connection in the	Connector	Stop bracket	Total weight [kg]
End grain area	Lifting Anchor Ø 40 mm + 8 x VSS 6 x 60	$\beta$	with two strands
		30°	255
		45°	360
		60°	441
		75°	492
		$\beta$	with n strands
		90°	n x 255

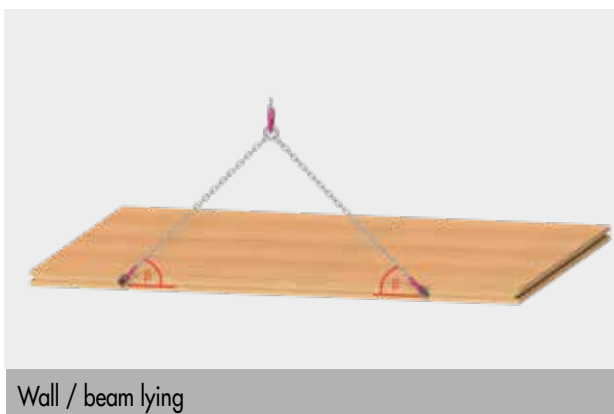

Wall / beam lying



Wall / beam standing

# PRODUCT DATA SHEET

# LIFTING ANCHOR

HORIZONTAL WALL OR BEAM: SET UPRIGHT, THEN LIFT

CLT wall or beam				
Connection in the	Connector	Stop bracket	Total weight [kg]	
		$\beta$	with two strands	
End grain area	Lifting Anchor $\varnothing$ 40 mm + 8 x VSS 6 x 60	30°	444	
		45°	528	
		60°	569	
		75°	588	
		$\beta$	with n strands	
		90°	n x 297	

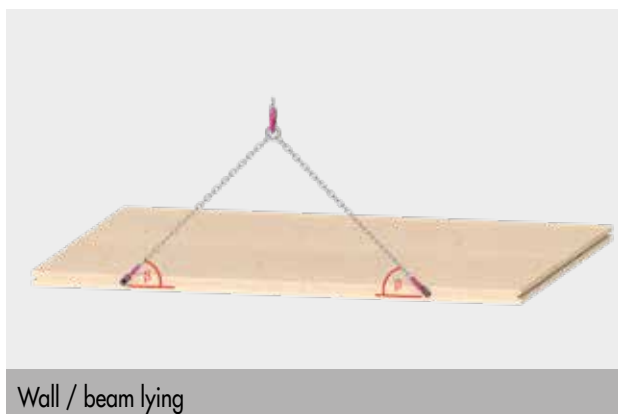

Wall / beam lying

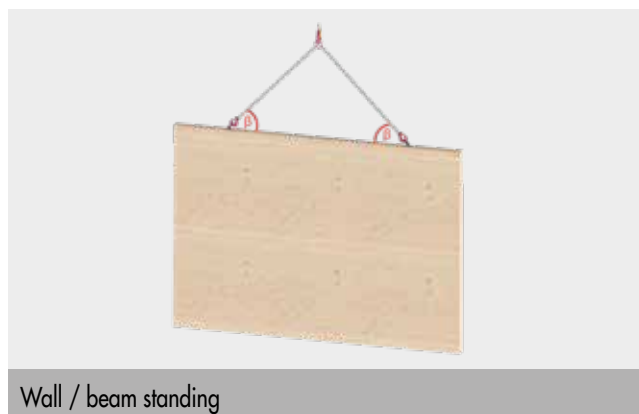

Wall / beam standing

## NOTES:

- The tables are based on the expert evaluation report entitled "Loadcarrying Capacity of Connections with E.u.r.o. Tec Lifting Anchors" by H.J. Blaß, 30/03/2020.
- The tables illustrate the 'Setting upright and subsequently lifting a horizontal wall or horizontal beam' load case (lifting from a horizontal position leading to vertical suspension).
- The connectors must be screwed into the components' centre plane flush, plus perpendicular to the surfaces of the narrow sides and side or end grain areas.
- According to the above-mentioned expert report, a vibration coefficient of min.  $\varphi = 2.0$  must be used.
- The values stated in the table take a vibration coefficient of  $\varphi = 2.0$  into account. For deviating vibration coefficients, the table values must be multiplied by the factor  $2.0/\varphi$ .
- Whether transverse tensile reinforcement is required for lifting depends on the component to be lifted and must be decided by the manufacturer of the component to be lifted.

# PRODUCT DATA SHEET

# LIFTING ANCHOR

VERTICAL WALL OR BEAM: LIFT

Glue-laminated timber beams			
Connection in the	Connector	Stop bracket	Total weight [kg]
Side area	Lifting Anchor Ø 40 mm + 8 x VSS 6 x 60	β	with two strands
		30°	659
		45°	929
		60°	929
		75°	929
		β	with n strands
		90°	n x 464

Glue-laminated timber wall			
Connection in the	Connector	Stop bracket	Total weight [kg]
End grain area	Lifting Anchor Ø 40 mm + 8 x VSS 6 x 60	β	with two strands
		30°	288
		45°	482
		60°	759
		75°	1170
		β	with n strands
		90°	n x 743

CLT wall or beam			
Connection in the	Connector	Stop bracket	Total weight [kg]
Narrow surface	Lifting Anchor Ø 40 mm + 8 x VSS 6 x 60	β	with two strands
		30°	601
		45°	886
		60°	1135
		75°	1311
		β	with n strands
		90°	n x 688



## PRODUCT DATA SHEET

## LIFTING ANCHOR

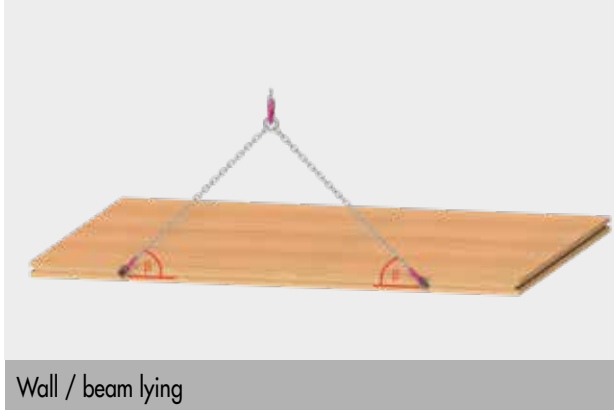

Wall / beam lying



Wall / beam standing

### NOTES:

- The tables are based on the expert evaluation report entitled "Loadcarrying Capacity of Connections with E.u.r.o. Tec Lifting Anchors" by H.J. Blaß, 30/03/2020.
- The tables illustrate an example of "Lifting a standing wall or beam".
- The connectors must be screwed into the components' centre plane flush, plus perpendicular to the surfaces of the narrow sides and side or end grain areas.
- According to the above-mentioned expert report, a vibration coefficient of min.  $\varphi = 2.0$  must be used.
- The values stated in the table take a vibration coefficient of  $\varphi = 2.0$  into account. For deviating vibration coefficients, the table values must be multiplied by the factor  $2.0/\varphi$ .
- Whether transverse tensile reinforcement is required for lifting depends on the component to be lifted and must be decided by the manufacturer of the component to be lifted.

# PRODUCT DATA SHEET

# LIFTING ANCHOR

## LIFT THE HORIZONTAL CEILING

Glue-laminated timber beams				
Connection in the	Connector	Stop bracket $\beta$	Ground plan bracket $\delta$	Total weight [kg] with four strands
Side area	Lifting Anchor $\varnothing$ 40 mm + 8 x VSS 6 x 60	30°	5°	1308
			15°	1229
			25°	1114
			35°	1000
			45°	905
			60°	804
			75°	749
		45°	5°	1859
			15°	1838
			25°	1704
			35°	1563
			45°	1439
			60°	1301
			75°	1222
		60°	5°	1858
			15°	1858
			25°	1858
			35°	1858
			45°	1858
			60°	1858
			75°	1830
		75°	5°	1858
			15°	1859
			25°	1859
			35°	1858
			45°	1858
			60°	1858
			75°	1858
		$\beta$	$\delta$	with two strands
		30°	0°	659
90°	366			
45°	0°	929		
	90°	598		
60°	0°	929		
	90°	900		
75°	0°	929		
	90°	929		
$\beta$	$\delta$	with n strands		
90°	0°	n x 464		

# PRODUCT DATA SHEET

# LIFTING ANCHOR

		CLT ceiling		
Connection in the	Connector	Stop bracket	Ground plan bracket	Total weight [kg]
		$\beta$	$\delta$	with four strands
Side area	Lifting Anchor $\varnothing$ 40 mm + 8 x VSS 6 x 60	30°	5°	1193
			15°	1121
			25°	1015
			35°	911
			45°	824
			60°	732
			75°	682
		45°	5°	1762
			15°	1683
			25°	1559
			35°	1429
			45°	1314
			60°	1187
			75°	1091
		60°	5°	2262
			15°	2205
			25°	2108
			35°	1995
			45°	1887
			60°	1756
			75°	1649
		75°	5°	2620
			15°	2600
			25°	2564
			35°	2518
			45°	2469
			60°	2401
			75°	2339
		$\beta$	$\delta$	with two strands
		30°	0°	1203
90°	333			
45°	0°	1773		
	90°	545		
60°	0°	2270		
	90°	824		
75°	0°	2623		
	90°	1169		
$\beta$	$\delta$	with n strands		
90°	0°	n x 688		

## PRODUCT DATA SHEET

## LIFTING ANCHOR

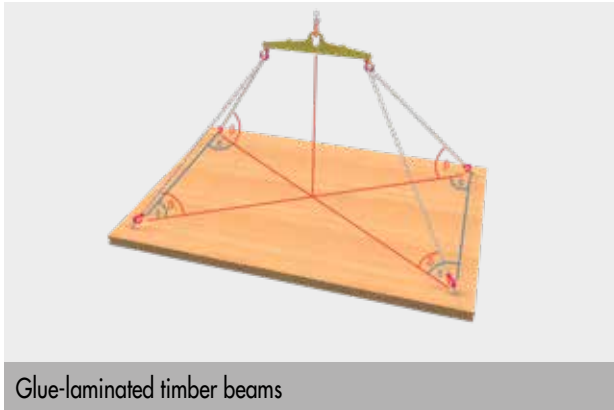

Glue-laminated timber beams

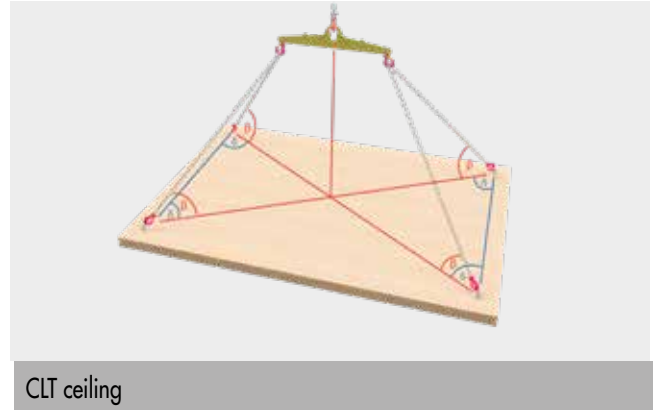

CLT ceiling

### NOTES:

- The tables are based on the expert evaluation report entitled "Loadcarrying Capacity of Connections with E.u.r.o. Tec Lifting Anchors" by H.J. Blaß, 30/03/2020.
- The tables illustrate an example of "Lifting of horizontal ceiling elements".
- The connectors must be attached in flush with the surface, plus perpendicular to the component surface.
- According to the above-mentioned expert report, a vibration coefficient of min.  $\varphi = 2.0$  must be used.
- The values stated in the table take a vibration coefficient of  $\varphi = 2.0$  into account. For deviating vibration coefficients, the table values must be multiplied by the factor  $2.0/\varphi$ .
- For this type of use, load beams must be used.

### PRODUCT TABLE

Lifting Anchor Ø 40 mm						
Art. no.	Designation	Dimensions [mm] <sup>a)</sup>	Number of screws			PU
944892	Lifting Anchor	80 x Ø 40	8			4
Ball supporting bolt						
Art. no.	Designation	Dimensions [mm] <sup>a)</sup>	F <sub>1</sub> [kN]	F <sub>2</sub> [kN]	F <sub>3</sub> [kN]	PU
944893	Ball supporting bolt	50 x Ø 20	10	8,5	6,5	1

<sup>a)</sup> Height x Diameter

If you are not familiar with how this product is used, and particularly with the product's intended use, please contact our Application Technology department (technik@eurotec.team).