

PRODUCT DATA SHEET

U POST HOLDER

PRODUCT DESCRIPTION

The U-shaped post holders made of hot-dip galvanized steel are ideal for securely fastening square timber posts. The side support keeps the timber post raised off the ground, which prevents waterlogging and extends the wood's lifespan. Installation is secure, using three screws anchored in the ground. Thanks to the hot-dip galvanization, the post holder is particularly corrosion-resistant and durable — perfect for use outdoors.



SPECIFICATIONS

- Suitable for wooden posts in gardening and landscaping: Fences, privacy screens, pergolas, or carports
- Ensures the post is securely anchored and properly aligned
- Prevents the wood from coming into direct contact with the floor and reduces moisture damage
- Low-maintenance thanks to its weather-resistant surface

MATERIAL

- Steel, hot-dip galvanized

PRODUCT TABLE

Art. no.	Dimensions [mm]	PU
904717	71 x 150	1
904719	91 x 150	1
904721	101 x 150	1

TECHNICAL INFORMATION

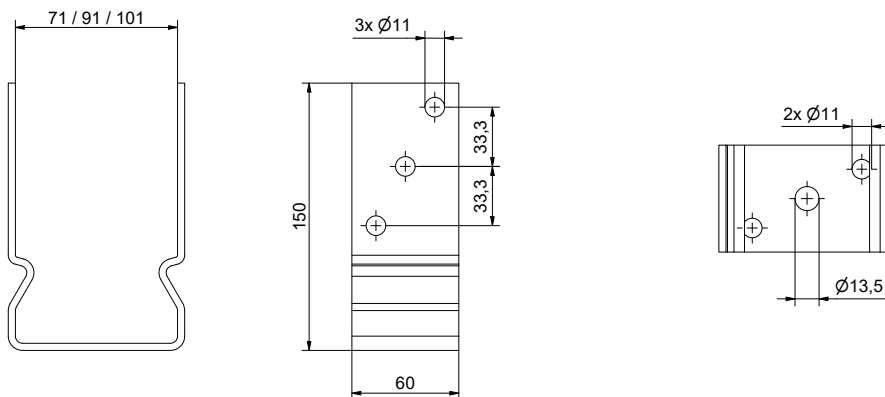

If you are unfamiliar with the application of this product, particularly its intended use, please be sure to contact our Application Engineering department (technik@eurotec.team).