

PRODUCT DATA SHEET

BEAM PRESS

PRODUCT DESCRIPTION

The ratchet-operated beam pusher is an essential tool for tradespeople. Whether you're straightening a crooked wall or installing pre-fabricated timber elements, the beam pusher allows you to position timber wall elements quickly and easily.



ADVANTAGES

- Minimal marks left on the wood thanks to fixing with Wood construction screws
- Suitable for types of wood with an increased risk of cracking and splitting
- Easy straightening of components
- 90° angle as a stop point
- Large contact surface to prevent the beam pusher from being pressed into the wood

SPECIFICATIONS

- Stop bracket
 - 10 x slotted holes, 8.5 mm each
- Fixing plate
 - 4 x Ø 8.5 (wood fixing)
 - 1 x Ø 11 (concrete fixing)

PRODUCT DATA SHEET

BEAM PRESS

IMAGES OF APPLICATIONS



PRODUCT DATA SHEET

BEAM PRESS

TECHNICAL INFORMATION

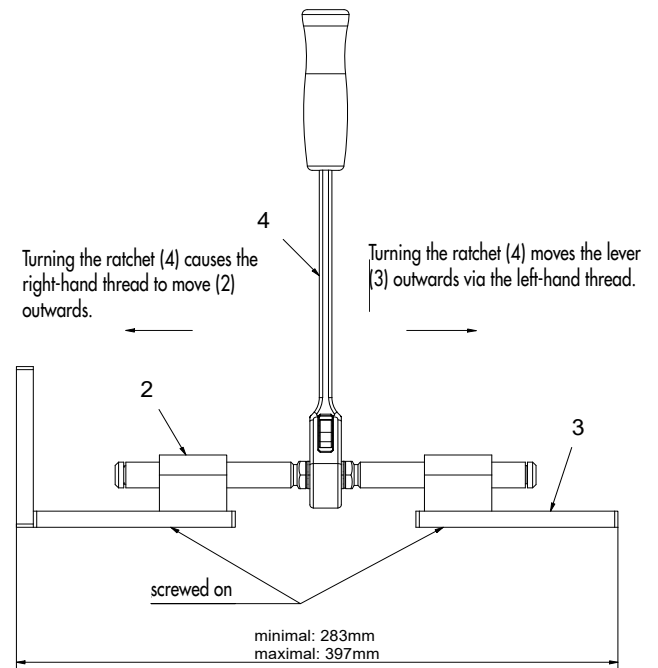
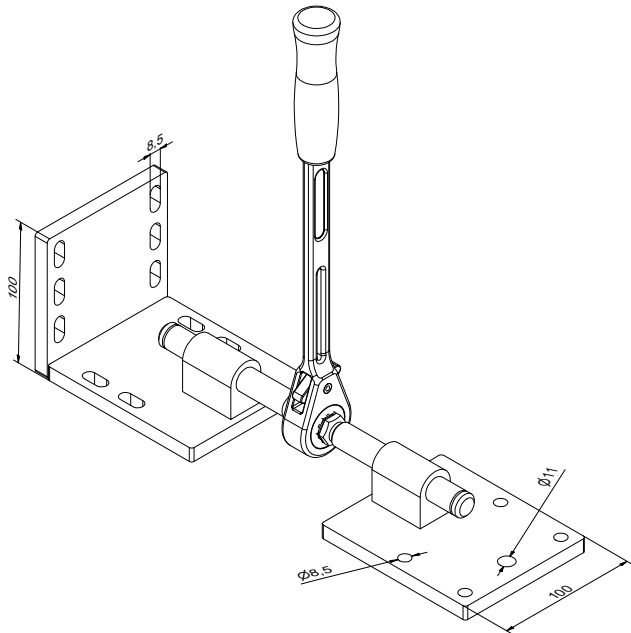

PRODUCT TABLE

Beam press			
Art. no.	Span [mm]		PU
954059	max. 397		1

If you are unfamiliar with the application of this product, particularly its intended use, please be sure to contact our Application Engineering department (technik@eurotec.team).