

Product data sheet – Angle bracket with a rib

Product description - Angle bracket with a rib 70 x 70 x 55 mm

Our angle connector can be used to fasten wooden joists to masonry and concrete, or for wood connections. The connector's high stability, provided by the reinforcement bead, allows connections with high bearing capacities.



Material

- S 250 GD + Z 275

Article table

Angle bracket with a rib 70 x 70 x 55 mm				
Art. no.	Dimensions [mm] ^{a)}	Material thickness T [mm]	Drilling [mm] ^{b)}	PU
904725	70 x 70 x 55	2,0	12 x 5 / 2 x 11	100

a) Length x height x width

b) Quantity x Ø L

Assembly

The angle connectors are fixed in the wood with special nails/comb nails Ø 4.0 x 40 mm, load-bearing capacity class 3/C, profiled nail length $l_{ef} \geq 31$ mm, bolt Ø 10 mm with min. (NRk; VRk) = 5 kN.

Product data sheet – Angle bracket with a rib

Drawing

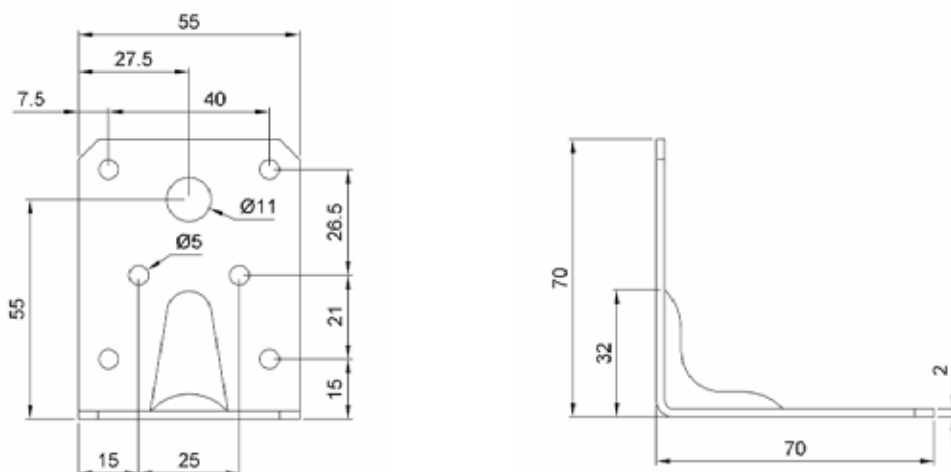

Product description - Angle bracket with a rib 90 x 90 x 65 mm

The angle connector with reinforcing rib can be used to fasten squared timbers to masonry, concrete etc. as well as wood/wood joints. The reinforcing rib gives the connector a high stability and is particularly suitable for connections where high forces have to be transmitted.

Material

- S 250 GD + Z 275



Product data sheet – Angle bracket with a rib

Article table

Angle bracket with a rib 90 x 90 x 65 mm				
Art. no.	Dimensions [mm] ^{a)}	Material thickness T [mm]	Drilling [mm] ^{b)}	PU
904726	90 x 90 x 65	2,5	20 x 5 / 2 x 11	100

a) Length x height x width

b) Quantity x Ø L

Assembly

The angle connectors are fixed in the wood with special nails / comb nails $\varnothing 4.0 \times 40$, load capacity class 3/C, profiled nail length $l_{ef} \geq 31$ mm, bolt $\varnothing 10$ mm with min. (NRk; VRk) = 5 kN.

Drawing

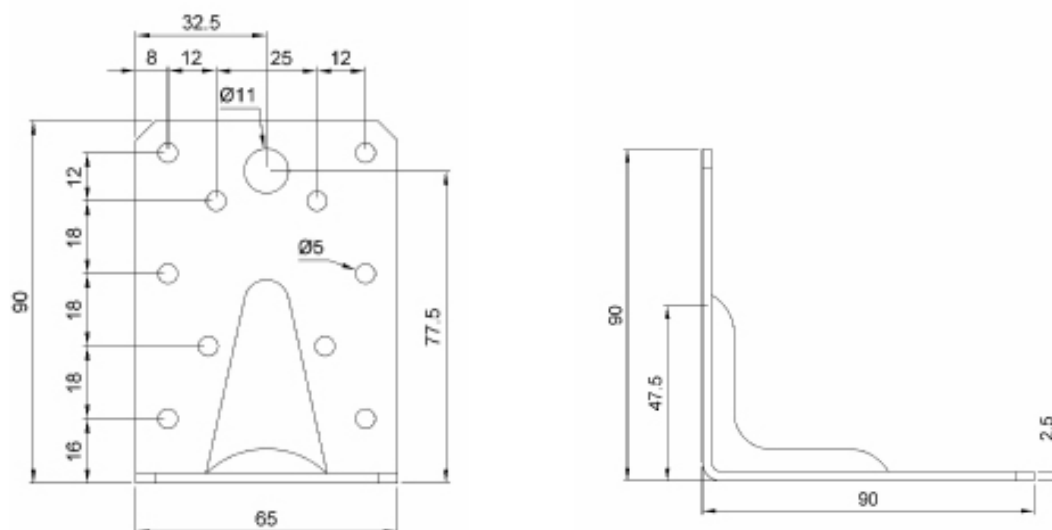

Product data sheet – Angle bracket with a rib

Product description - Angle bracket with a rib 100 x 100 x 90 mm

The angle connector with reinforcing rib can be used to fasten squared timbers to masonry, concrete etc. as well as wood/wood joints. The reinforcing rib gives the connector a high stability and is particularly suitable for connections where high forces have to be transmitted.



Material

- S 250 GD + Z 275

Article table

Angle bracket with a rib 100 x 100 x 90 mm				
Art. no.	Dimensions [mm] ^{a)}	Material thickness T [mm]	Drilling [mm] ^{b)}	PU
904727	105 x 105 x 90	3,0	28 x 5 / 6 x 11	50

a) Length x height x width

b) Quantity x Ø L

Assembly

The angle connectors are fixed in the wood with special nails / comb nails Ø 4.0 x 40, load capacity class 3/C, profiled nail length $l_{ef} \geq 31$ mm, bolt Ø 10 mm with min. (NRk; VRk) = 5 kN.

Product data sheet – Angle bracket with a rib

Drawing

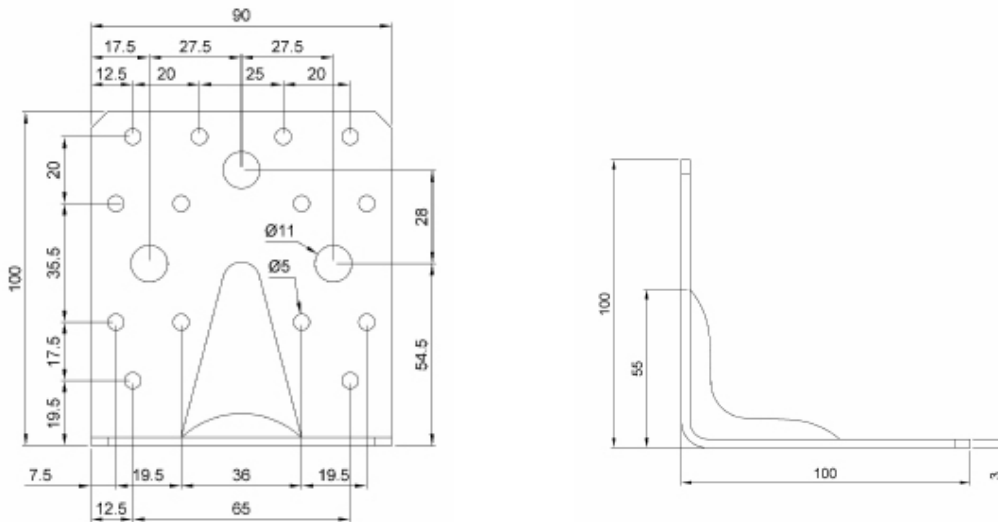

Product description - Angle bracket with a rib 110 x 170 x 95 mm

The angle connector with reinforcing rib can be used to fasten squared timbers to masonry, concrete etc. as well as wood/wood joints. The reinforcing rib gives the connector high stability and is particularly suitable for connections where high forces have to be transmitted.

Material

- S 250 GD + Z 275



Product data sheet – Angle bracket with a rib

Article table

Angle bracket with a rib 110 x 170 x 95 mm				
Art. no.	Dimensions [mm] ^{a)}	Material thickness T [mm]	Drilling [mm] ^{b)}	PU
904729	110 x 170 x 55	3,0	53 x 5 / 9 x 13	25
904725	70 x 70 x 55	2,0	12 x 5 / 2 x 11	100
904726	90 x 90 x 65	2,5	20 x 5 / 2 x 11	100
904727	105 x 105 x 90	3,0	28 x 5 / 6 x 11	50

a) Length x height x width

b) Quantity x Ø L

Assembly

The angle connectors are fixed in the wood with special nails / comb nails Ø 4.0 x 40, load capacity class 3/C, profiled nail length $l_{ef} \geq 31$ mm, bolt Ø 12 mm with min. (NRk; VRk) = 5 kN.

Drawing

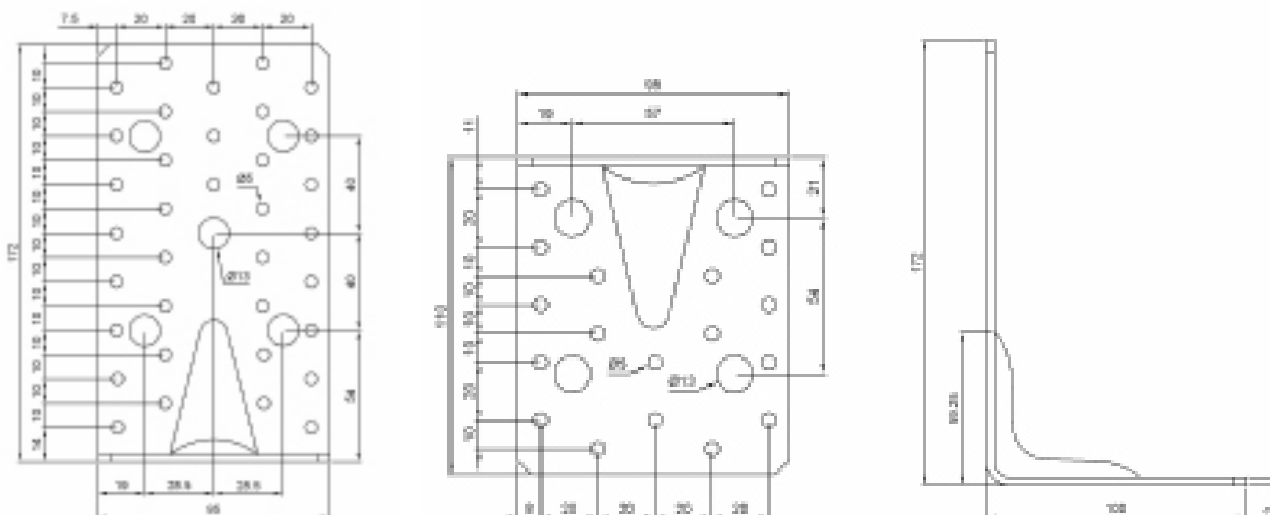

If you are not familiar with the application of the product at hand, especially with the handling according to given regulations, it is essential to get in contact with our technical application support department (Technik@eurotec.team).